



Republic of the Philippines  
**Department of Education**  
REGION XI  
SCHOOLS DIVISION OF DIGOS CITY

**REQUEST FOR QUOTATION**

**The Department of Education, Schools Division of Digos City**, through its Bids and Awards Committee, intends to invite eligible bidder for the **"PROCUREMENT AND DELIVERY of Repair Services for Project No. 24-12-149: Procurement of Services for the Repair of ASDS Office with Installation of Comfort Room & Lavatory at Digos City Division Office"** for CY 2024 in accordance with the provisions of the 2016 Revised Implementing Rules and Regulations of Republic Act No. 9184. The Approved Budget for the Contract (ABC) is **One Hundred Forty Nine Thousand Five Hundred Pesos Only (P149,500.00)**.

Please quote your **best offer** for the item/s described herein, **subject to the Terms and Conditions** provided at the last page of this Request for Quotation (RFQ). Submit your quotation duly signed by your authorized representative **not later than December 23, 2024, 9:30 AM** at the DepEd Schools Division Office-Digos City, Roxas cor. Lopez Jaena Street, Zone II, Digos City, Davao del Sur. **Quotations** may also be submitted through facsimile or email at the address and contact numbers indicated below.

A copy of your **2024 Business/Mayor's Permit and PhilGEPS Registration Number** is also required to be submitted along with your signed quotation/proposal. A valid Certificate of PhilGEPS Registration (Platinum Membership) may be submitted in lieu of the Mayor's/Business Permit.

For any clarification, you may contact us at telephone no. **(082)-553-8396**, or email address at [bac.digoscity@deped.gov.ph](mailto:bac.digoscity@deped.gov.ph).

**MARIA GENEVIEVE T. FRANCISQUETE, Ed.D.**

*BAC Chairperson*

For and in the absence of the Chairperson:

**CLARENCE S. PILLERIN**

*BAC Vice-Chairperson*



<b>Payment Details:</b>	Payment shall be made promptly, but in no case later than sixty (60) days, through Land Bank's LDDAP-ADA/Bank Transfer facility after submission of billing statement/invoice and upon fulfillment of other obligations as stipulated in the contract as well as upon inspection and acceptance of the goods by the end user.
<b>Banking Institution</b>	
<b>Account Number</b>	
<b>Account Name</b>	
<b>Branch</b>	

<b><u>SCHEDULE OF REQUIREMENTS</u></b>	
The delivery schedule expressed as weeks/months stipulates hereafter the delivery date to the project site.	
<b><u>SCHEDULE OF REQUIREMENTS</u></b>	<b><u>Delivery Schedule</u></b>
<b>Delivery of goods/supplies (enumerated under Technical Specifications)</b>	<b>Seventy-five (75) days</b>

<b><u>TERMS AND CONDITIONS:</u></b>
<p>1. Bidders shall provide correct and accurate information required in this form.</p> <p>2. Price quotation/s must be valid for a period of sixty (60) calendar days from the date of submission of quotation.</p> <p>3. Price quotation/s, to be denominated in Philippine peso shall include all taxes, duties and/or levies payable.</p> <p>4. Quotations exceeding the Approved Budget for the Contract shall be rejected.</p> <p>5. Award of contract shall be made to the lowest calculated and responsive quotation (for goods and infrastructure) or, the highest rated offer (for consulting services) which complies with the minimum technical specifications and other terms and conditions stated herein.</p> <p>6. Any interlineations, erasures or overwriting shall be valid only if they are signed or initialed by you or any of your duly authorized representative/s.</p> <p>7. The item/s shall be delivered according to the requirements specified in the Technical Specifications.</p> <p>8. The DepED shall have the right to inspect and/or to test the goods to confirm their conformity to the technical specifications.</p> <p>9. In case two or more bidders are determined to have submitted the Lowest Calculated Quotation/Lowest Calculated and Responsive Quotation, DepED shall adopt and employ "draw lots" as the tie-breaking method to finally determine the single winning provider in accordance with GPPB Circular 06-2005.</p> <p>10. <b>Payment shall be processed after delivery and upon the submission of the required supporting documents, in accordance with existing government accounting rules and regulations. Please note that the corresponding bank transfer fee, if any, shall be chargeable to the contractor's account.</b></p>

\_\_\_\_\_  
Signature over printed name

\_\_\_\_\_  
Office Telephone/Fax/Mobile no.

\_\_\_\_\_  
Position/Designation

\_\_\_\_\_  
Email address/es

**Canvassed by:**

\_\_\_\_\_  
Signature over printed name

\_\_\_\_\_  
Date



**PROGRAM OF WORKS**  
**DETAILED COST ESTIMATE**

**Project Title: Repair of ASDS Office with installation of Comfort Room & Lavatory**

Location : Digos City Division Office

Description	Quantity	Unit	Unit Cost	Amount
<b>A. General Requirements</b>				
Clearing & Hauling	1.0	lot		
Demolition Works (Wall & Flooring)	1.0	lot		
<b>Sub-total Labor</b>				
<b>B. Wall Partition &amp; Painting Works</b>				
2" x 4" x 1.2mm thk. Square Tube	5.0	length		
Fiber Cement Board 4.5mm thk.	5.0	shts		
welding rod 6011 special	2.0	kg		
# 4 cutting disk	6.0	pc		
epoxy gray primer paint	1.0	gal		
laquer thinner	1.0	gal		
paint brush 4"	2.0	pc		
paint Roller 8"	4.0	pc		
Cementitious Waterproofing	2.0	sq.m		
Enamel, Flatwall	2.0	gal		
Enamel, Semi Gloss	8.0	gal		
Glazing Putty	4.0	gal		
Paint Thinner	1.0	gal		
<b>Sub-total Materials</b>				
Labor				
<b>C. Window, Doors &amp; Partition</b>				
Glass Partition with fixed glass and sliding glass complete with accessories	1.0	lot		
Hollow Core Flush Type Swing Door on 50mm x 150mm Wooden Jamb with Hardware and Accessories on Lever Type Door Knob.	1.0	lot		
Cladding for Window Opening with Frames and Accessories at CR area only	1.0	lot		
<b>Sub-total Labor &amp; Materials</b>				
<b>D. Tile Works</b>				
Unglazed Floor Tiles 60cm x 60cm	8.0	pc		
Ceramic Floor Tiles 60cm x 60cm	6.0	pc		
Portland Cement	1.0	bags		
Tile Adhesive 25 kg/bag	2.0	bags		
Tile Grout 5 kg/bag	1.0	bags		
Tile Trim	1.0	length		
<b>Sub-total Materials</b>				
Labor				

<b>E. Waterline &amp; Plumbing Fixtures</b>			
Water Closet 1.6gpf with accessories & Bidet	1.0	set	
Stainless Kitchen Sink with P-Trap & Accessories	1.0	set	
Water Closet Flange	1.0	set	
Faucet / Hose Bibb, Brass 1/2"DIA	1.0	pcs	
S.S Floor Drain 4"x4"	2.0	pcs	
PP-R Pipe 1/2Ø x 4.0m	3.0	pcs	
PP-R Bends & Accessories	1.0	lot	
Gate Valve, 1/2"Ø	1.0	pc	
<b>Sub-total Materials</b>			
Labor			
<b>F. Sewer Line Works</b>			
PVC Sanitary Pipe 4"DIA x 3.0m	1.0	pcs	
PVC Sanitary Pipe 2"DIA x 3.0m	1.0	pcs	
PVC Bends and P-Trap	1.0	lot	
Cleanout 4"x4"	2.0	pcs	
PVC Solvent	2.0	can	
<b>Sub-total Materials</b>			
Labor			
<b>G. CONCRETE &amp; MASONRY WORKS</b>			
<b>Earthworks</b>			
Structural Excavation	5.2	cu.m	
Gravel Bedding G-1	0.5	cu.m	
<b>Concreting Works</b>			
Septic Vault Slab	1.0	cu.m	
Portland Cement	9.0	bag	
Crushed Gravel 3/4"	1.0	cu.m	
Washed Sand	1.0	cu.m	
<b>Rebar Works</b>			
Septic Vault Slab			
Deformed Round Bars, Grade 40	40.0	kg	
G.I. Tie Wire	3.0	kg	
<b>Formworks</b>			
Coco Lumber	40.0	bd.ft	
Plywood Ordinary, 1/4" x 4' x 8'	2.0	pc	
CWN, Assorted	2.0	kg	
<b>Masonry Works</b>			
Septic Vault CHB Wall	15.0	sq.m	
CHB 4" thk	188.0	pc	
Portland Cement	5.0	bag	
Washed Sand	1.0	cu.m	
10mm x 6m RSB	20.0	kg	
G.I. Tie Wire	1.0	kg	
Plastering	30.0	sq.m	
Portland Cement	10.0	bag	
Washed Sand	1.0	cu.m	
<b>Sub-total Materials</b>			
Labor			

<b>H. Electrical Works</b>				
3.5 mm <sup>2</sup> THHN/THWN-2 Wire Stranded	42.0	m		
Weather Proof Convenience Outlet, 3 Prong, 2 Gang, 20A, 230V	1.0	pcs		
Duplex, Convenience Outlet, Universal, Grounding Type 20A, 250V	3.0	pcs		
2 Single Pole Switch in one Switch Plate ( 10A, 230V)	1.0	pcs		
Utility Box, PVC, Surface Type	4.0	pcs		
1 x 18 W, 230V, 60Hz AC Compact Fluorescent/LED Down Lighting Fixture	2.0	pcs		
PVC Junction Box	2.0	pcs		
Exhaust Fan Wall	1.0	pcs		
3/4" Plastic Moulding, White, 3/4" x 8'	3.0	length		
Tux and Screw 3/4"	1.0	set		
<b>Sub-total Materials</b>				
Labor				
<b>MATERIALS</b>				
<b>LABOR &amp; CONTIGENCY</b>				
<b>GRAND TOTAL</b>				

Prepared by :

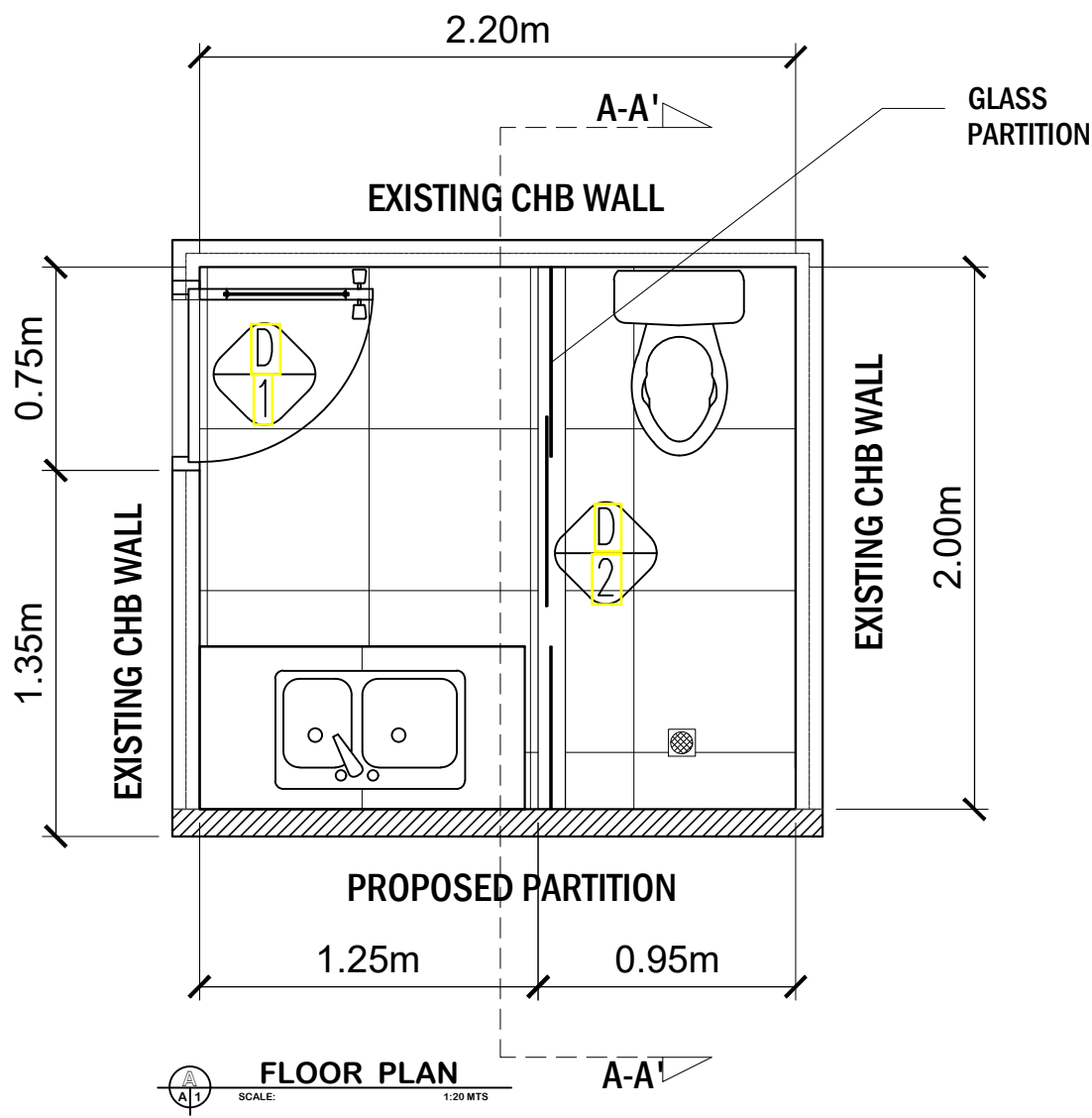

**FLOOR AREA**

PANTRY AREA = 1.25m X 2.00m

T & B = 0.95m X 2.00m

**FLOOR PLAN**  
 SCALE: 1:20 MTS  
 A-A'

<b>PREPARED BY:</b> ENGR. EMMANUEL FREDERICK C. ALCOBA DEPED PROJECT ENGINEER	<b>CHECKED &amp; REVIEWED:</b> ENGR. HELEN N. FRANCONAS DEPED DIVISION ENGINEER	<b>RECOMMENDING APPROVAL:</b> SOLLIE B. OLIVER CHIEF SGOD	<b>APPROVED BY:</b> MELANIE P. ESTACIO, CESO VI SCHOOLS DIVISION SUPERINTENDENT	<b>PROJECT TITLE:</b> REPAIR OF ASDS OFFICE WITH INSTALLATION OF COMFORT ROOM & LAVATORY. <b>LOCATION:</b> DEPED DIGOS CITY DIVISION	Drawings and specifications, and other contract documents duly signed, stamped or sealed, as instruments of service, are the intellectual property and documents of the Architect, whether the object for which they are made is executed or not. It shall be unlawful for any person to duplicate or make copies of said documents for use in the repetition of and for the other projects or buildings, whether executed partly or in whole, without the written consent of the Architect or author of the said documents.	<b>SHEET NO. :</b>  <b>PROJECT NO. :</b>
---	---	---	---	---	--	---

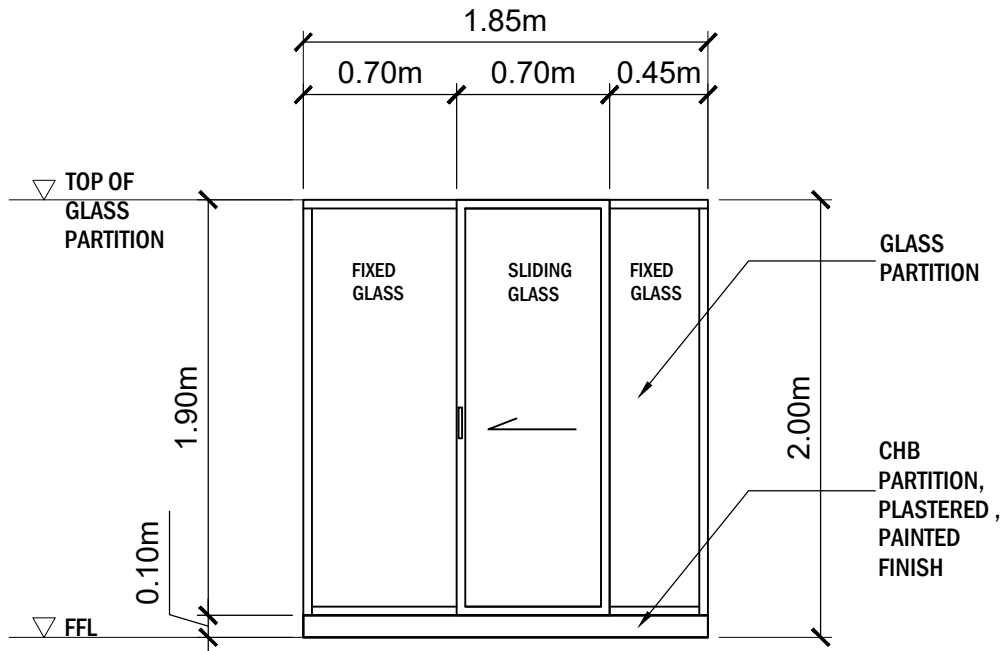

**SECTION THRU A-A'**  
SCALE: 1:25 MTS

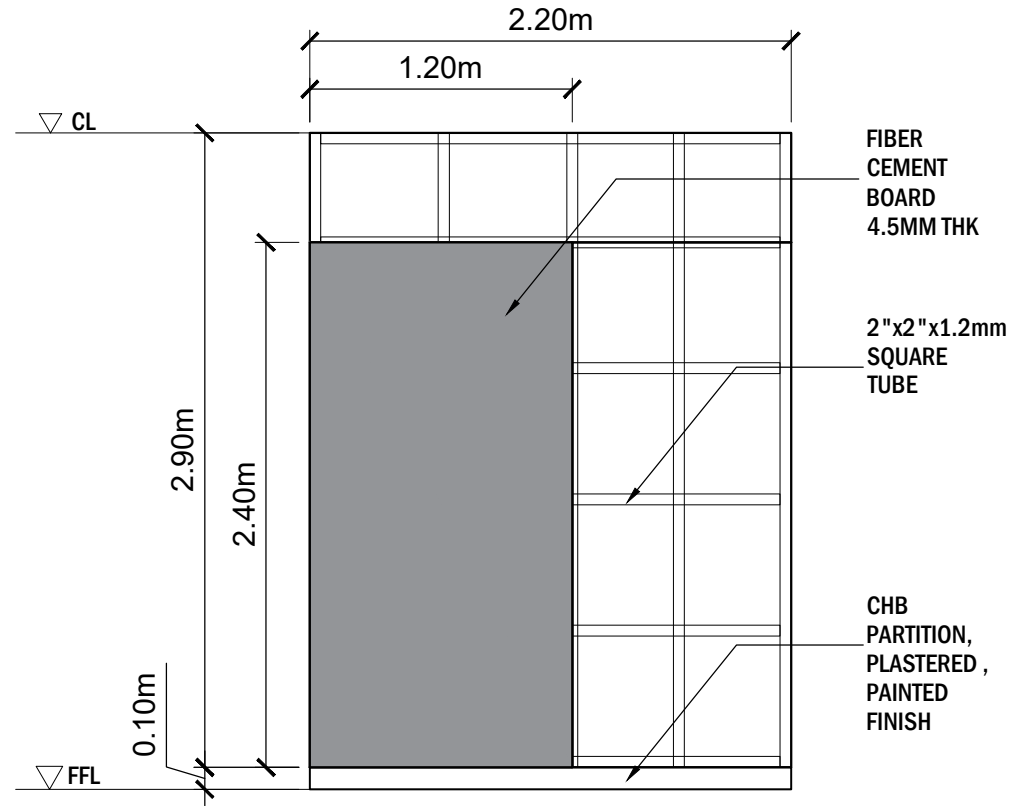

**WALL PARTITION**  
SCALE: 1:25 MTS

<b>PREPARED BY:</b> ENGR. EMMANUEL FREDERICK C. ALCOBA DEPED PROJECT ENGINEER	<b>CHECKED &amp; REVIEWED:</b> ENGR. HELEN N. FRANCONAS DEPED DIVISION ENGINEER	<b>RECOMMENDING APPROVAL:</b> SOLLIE B. OLIVER CHIEF SGOD	<b>APPROVED BY:</b> MELANIE P. ESTACIO, CESO VI SCHOOLS DIVISION SUPERINTENDENT	<b>PROJECT TITLE:</b> REPAIR OF ASDS OFFICE WITH INSTALLATION OF COMFORT ROOM & LAVATORY. <b>LOCATION:</b> DEPED DIGOS CITY DIVISION	Drawings and specifications, and other contract documents duly signed, stamped or sealed, as instruments of service, are the intellectual property and documents of the Architect, whether the object for which they are made is executed or not. It shall be unlawful for any person to duplicate or make copies of said documents for use in the repetition of and for the other projects or buildings, whether executed partly or in whole, without the written consent of the Architect or author of the said documents.	<b>SHEET NO. :</b>  <b>PROJECT NO. :</b>
---	---	---	---	---	--	---



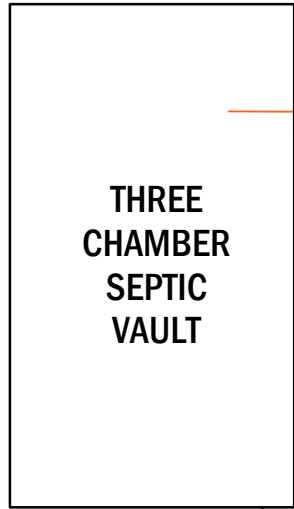

TO STREET SEWER

EXISTING CB

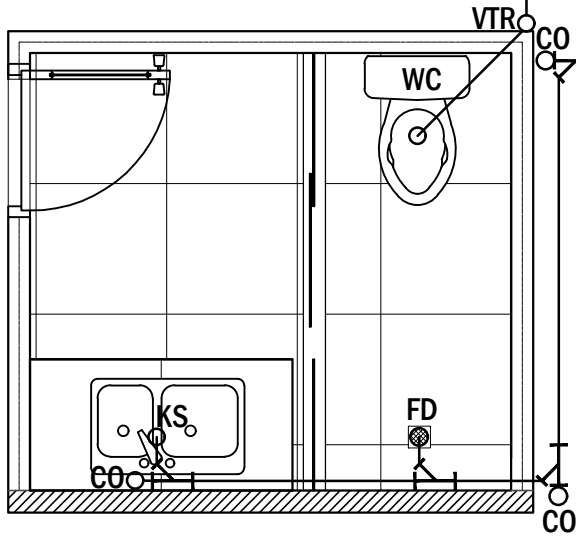

**SANITARY LAY-OUT**



SCALE:

1:25 MTS

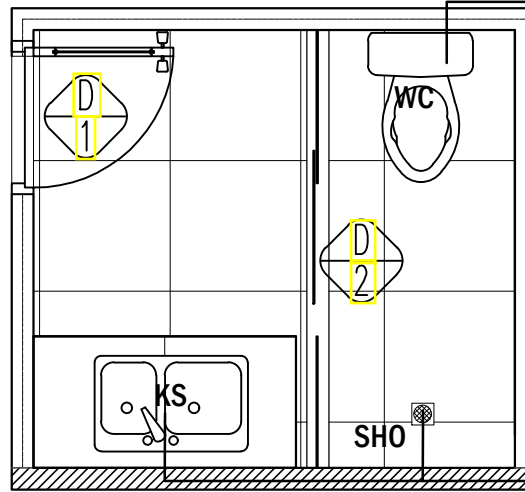

**WATER LINE LAY-OUT**

SCALE:

1:25 MTS

FROM NEAREST WATER SOURCE

**GENERAL INSTRUCTIONS**

**LEGEND**

- SV SEPTIC VAULT
- FAU FAUCET
- FD FLOOR DRAI
- CO CLEAN OUT
- MH MAN HOLE
- VTR VENT THRU ROOF
- HH HAND HOLE

- ALL PLUMBING WORKS SHALL CONFORM TO THE LATEST PROVISIONS OF THE NATIONAL PLUMBING CODE OF THE PHILIPPINES, THE NATIONAL BUILDING CODE AND THE RULES AND REGULATIONS OF THE CITY OR MUNICIPALITY.
- ALL WORKS SHALL BE DONE UNDER THE DIRECT SUPERVISION OF A REGISTERED MASTER PLUMBER.
- ALL MATERIALS SHALL BE OF ACCEPTED QUALITY, FREE FROM DEFECTS AND SUITABLE FOR BOTH LOCATION AND PURPOSE.
- WORKMANSHIP SHALL BE OF SUCH QUALITY AS TO SECURE THE RESULTS SPECIFIED BY THE PLUMBING CODE.

<p><b>PREPARED BY:</b> ENGR. EMMANUEL FREDERICK C. ALCOBA DEPED PROJECT ENGINEER</p>	<p><b>CHECKED &amp; REVIEWED:</b> ENGR. HELEN N. FRANCONAS DEPED DIVISION ENGINEER</p>	<p><b>RECOMMENDING APPROVAL:</b> SOLLIE B. OLIVER CHIEF SGOD</p>	<p><b>APPROVED BY:</b> MELANIE P. ESTACIO, CESO VI SCHOOLS DIVISION SUPERINTENDENT</p>	<p><b>PROJECT TITLE:</b> REPAIR OF ASDS OFFICE WITH INSTALLATION OF COMFORT ROOM &amp; LAVATORY.</p> <p><b>LOCATION :</b> DEPED DIGOS CITY DIVISION</p>	<p>Drawings and specifications, and other contract documents duly signed, stamped or sealed, as instruments of service, are the intellectual property and documents of the Architect, whether the object for which they are made is executed or not. It shall be unlawful for any person to duplicate or make copies of said documents for use in the repetition of and for the other projects or buildings, whether executed partly or in whole, without the written consent of the Architect or author of the said documents.</p>	<p><b>SHEET NO. :</b> 12</p> <p><b>PROJECT NO. :</b></p>
--	--	--	--	---	---	--

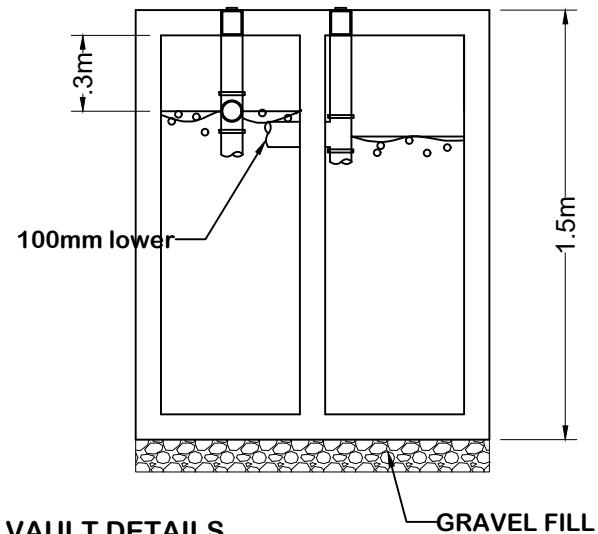
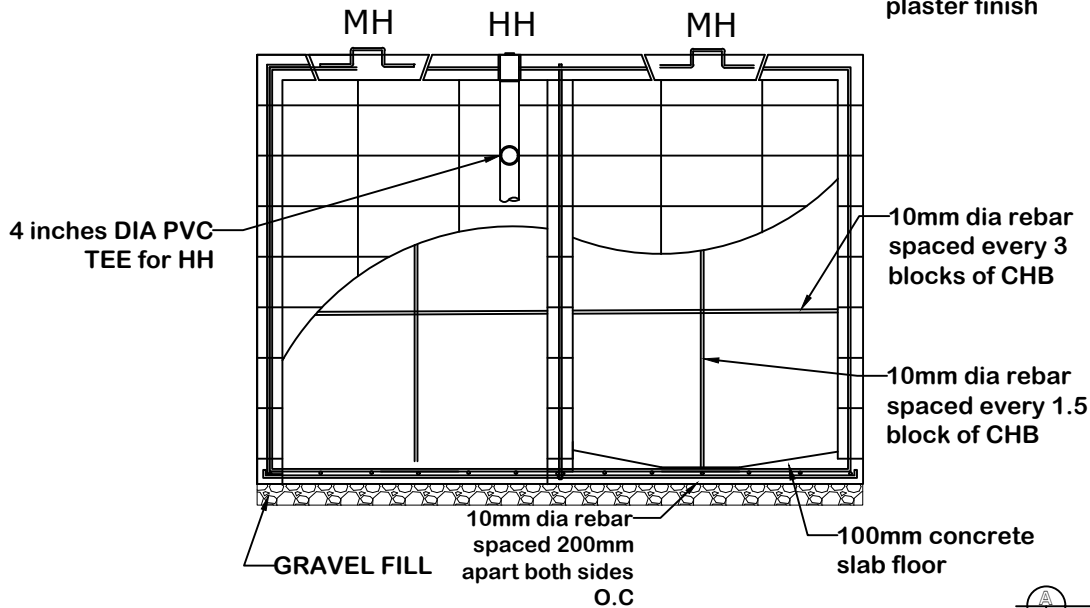
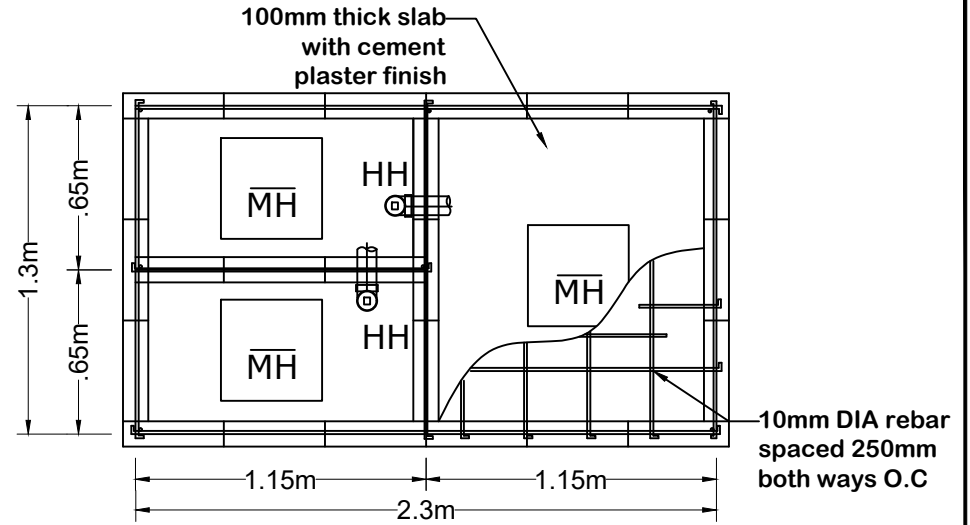
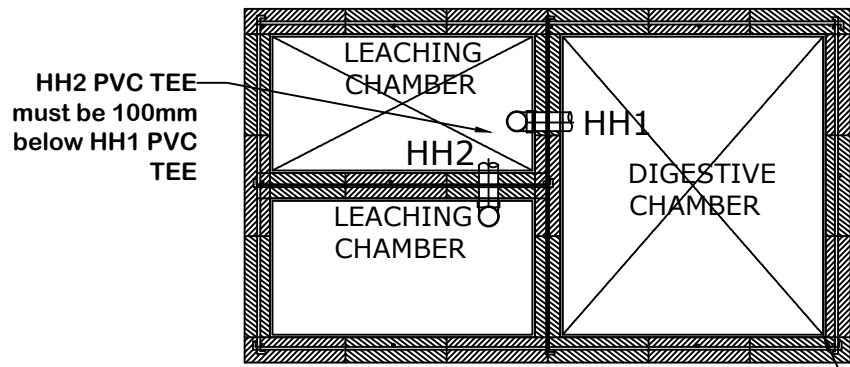

**SEPTIC VAULT DETAILS**  
SCALE: 1:20 MTS

<b>PREPARED BY:</b> ENGR. EMMANUEL FREDERICK C. ALCOBA DEPED PROJECT ENGINEER	<b>CHECKED &amp; REVIEWED:</b> ENGR. HELEN N. FRANCONAS DEPED DIVISION ENGINEER	<b>RECOMMENDING APPROVAL:</b> SOLLIE B. OLIVER CHIEF SGOD	<b>APPROVED BY:</b> MELANIE P. ESTACIO, CESO VI SCHOOLS DIVISION SUPERINTENDENT	<b>PROJECT TITLE:</b> REPAIR OF ASDS OFFICE WITH INSTALLATION OF COMFORT ROOM & LAVATORY. <b>LOCATION :</b> DEPED DIGOS CITY DIVISION	Drawings and specifications, and other contract documents duly signed, stamped or sealed, as instruments of service, are the intellectual property and documents of the Architect, whether the object for which they are made is executed or not. It shall be unlawful for any person to duplicate or make copies of said documents for use in the replication of and for the other projects or buildings, whether executed partly or in whole, without the written consent of the Architect or author of the said documents.	<b>SHEET NO. :</b>  PROJECT NO. :
---	---	---	---	---	---	--